

CHV-V/2V FREEZER

COMMERCIAL DISPLAY FREEZER – SELF CONTAINED



TABLE OF CONTENTS

ABOUT THIS MODEL **1**

MODEL 900 CHV/V **2**
Size
Specifications

MODEL 1100 CHV/V **4**
Size
Specifications

ABOUT THIS MODEL



- The most energy efficient double compressor system in South Africa
- Plug in – Self contained 220V
- Full European Standards HCCP certification (Hazardous Critical Control Points)
- Large Nett packing volume
- Hot Gas Technology – minimizing temperature fluctuations during defrost
- Flat Glass lids design with Italian manufactured tempered glass lids
- Additional 22% energy savings with Danfoss “On Demand cooling”
- FULL 3 year on site GUARANTEE
- Maintenance Free Refrigeration System
- High Ambient rating (+38 °C)
- Height adjustable shelves – Vertical/ horizontal
- Exterior in white PVC-coated galvanised steel
- Interior in non-toxic PVC-coated galvanised steel
- Copper tube evaporator and condenser
- Heated frame to reduce condensation and ice build-up
- Thermometer(s) to display internal temperature
- Bumper bar for protection against supermarket trolleys
- Easy-access front defrost drain
- Automatic Defrost
- CHV/V - Supplied with 1 pair of thermal glass sliding lids
- CHV/2V - Supplied with 2 pairs of longitudinal thermal glass sliding lids
- CHV/VF - Supplied with 2 pairs of transversal thermal glass sliding lids

CHV (CHV/V)	CHV ECO (CHV/V D)
Auto Defrost	No Auto Defrost
Internal Shelving Dividers	Baskets for Storage
Digital Controllers	Thermostat Controller
Available in Anthracite and White	Only Available in White

MODEL 900 CHV/V

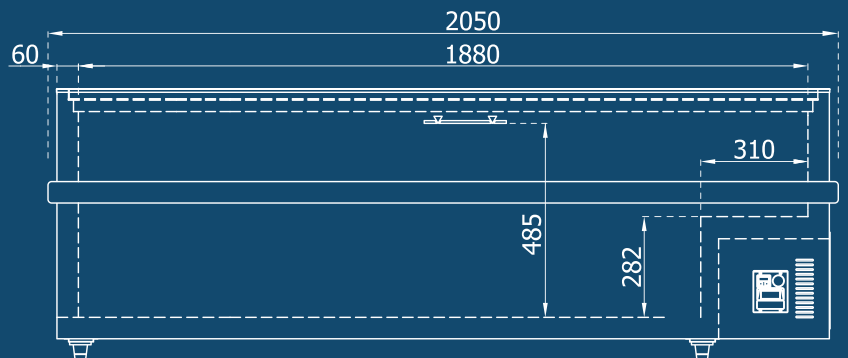
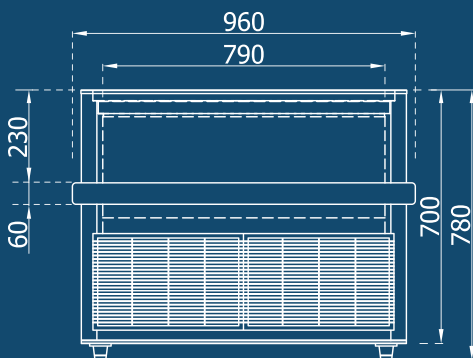
TECHNICAL SPECIFICATIONS





		900 CHV/V	900 CHV/V D
TECHNICAL DATA			
Total Display Area (TDA)	m ²	1.5	1.5
Climatic Class (EN23953)		3L1	3L1
Temperature Range	°C	-18/-28	-18/-28
Maintenance Free Condenser		✓	✓
Visual Alarm		•	✓
HACCP - Hazard Analysis & Critical Control Points		•	✓
Surveillance System		•	✓
Net Volume	lt	652	652
Gross Volume	lt	839	839
ELECTRICAL DATA			
Voltage/Frequency	V/Hz	230/50	230/50
Rated Power	W	356	356
Rated Current	A	1.8	1.8
Energy Consumption	kWh/24h	4.5	5.4
Energy Efficiency Index (EEI)		21.8	25.8
Efficiency Class	A to G		
REFRIGERANT DATA			
Refrigerant Type		R290	R290
Number of Compressors	Un	2	2
Maximum Operating Pressure	bar	30	30
DIMENSIONS & WEIGHT DATA			
Cabinet Dimensions	mm	2050x960x780	2050x960x780
Packaging Dimensions	mm	2140x1030x840	2140x1030x840
Net Weight	kg	105	105
Gross Weight	kg	160	160
ACCESSORIES INCLUDED			
Large Basket (AR050)	Un	1	1
Basket Divider (AR085)	Un	1	1
Small Basket (AR070)	Un	Not Available	Not Available
Max Number Baskets	Un	6 (6xAR050 + 1xAR051)	6 (6xAR050 + 1xAR051)
High Divider (AR097)	Un	2	2
Small Divider (AR096)	Un	1	1

MODEL 1100 CHV/V

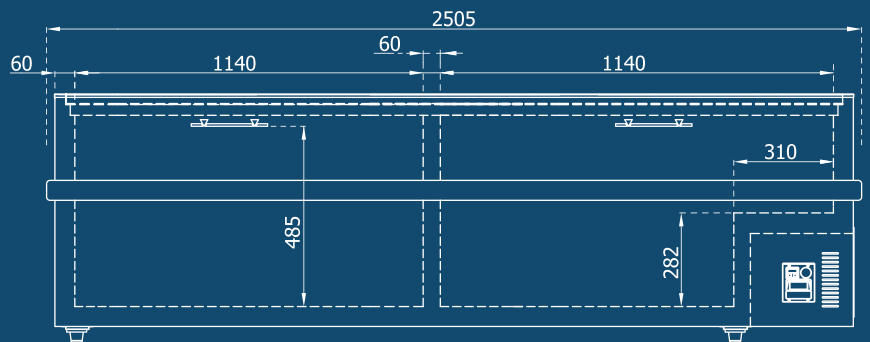
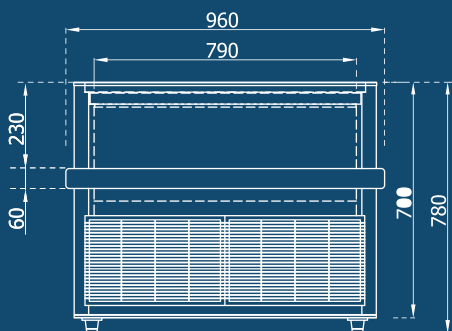
TECHNICAL SPECIFICATIONS



		1100 CHV/V	1100 CHV/V D
TECHNICAL DATA			
Total Display Area (TDA)	m ²	2.0	2.0
Climatic Class (EN23953)		3L1	3L1
Temperature Range	°C	-18/-28	-18/-28
Maintenance Free Condenser		✓	✓
Visual Alarm		•	✓
HACCP - Hazard Analysis & Critical Control Points		•	✓
Surveillance System		•	✓
Net Volume	lt	805	805
Gross Volume	lt	1032	1032
ELECTRICAL DATA			
Voltage/Frequency	V/Hz	230/50	230/50
Rated Power	W	356	356
Rated Current	A	1.8	1.8
Energy Consumption	kWh/24h	4.9	5.4
Energy Efficiency Index (EEI)		20.5	22.6
Efficiency Class	A to G		
REFRIGERANT DATA			
Refrigerant Type		R290	R290
Number of Compressors	Un	2	2
Maximum Operating Pressure	bar	30	30
DIMENSIONS & WEIGHT DATA			
Cabinet Dimensions	mm	2500x960x780	2500x960x780
Packaging Dimensions	mm	2590x1030x840	2590x1030x840
Net Weight	kg	125	125
Gross Weight	kg	200	200
ACCESSORIES INCLUDED			
Large Basket (AR050)	Un	1	1
Basket Divider (AR085)	Un	1	1
Small Basket (AR070)	Un	Not Available	Not Available
Max Number Baskets	Un	8 (7xAR050 + 1xAR051)	8 (7xAR050 + 1xAR051)
High Divider (AR097)	Un	2	2
Small Divider (AR096)	Un	1	1



CALL US
021 851 0511

EMAIL US
INFO@COOLDISPLAYS.CO.ZA

VISIT US
12 JULIAN WAY
SOMERSET WEST BUSINESS PARK
SOMERSET WEST, CAPE TOWN
SOUTH AFRICA

