

# DUPLA FREEZER

COMMERCIAL DISPLAY FREEZER – SELF CONTAINED



# TABLE OF CONTENTS

## ABOUT THIS MODEL

1

## DUPLA 2.2

2

Size  
Specifications

## DUPLA TOPO

4

Size  
Specifications

## ABOUT THIS MODEL



- Available versions:
  - (DE) automatic defrost freezer with automatic water evaporation.
  - (DEPN) automatic defrost freezer/cooler with automatic water evaporation.
- FULL 3 year guarantee.
- Energy saving R290 refrigerant.
- Maintenance free refrigeration.
- 2 x Compressor Multiplex type system (22% energy saving).
- Available in black or white.
- Auto defrosting of ice build up.
- Interior and exterior in white PVC coated galvanized steel.
- Warmed frame to avoid lids blockade.
- Digital temperature display to read the inside temperature.
- Adjustable Thermostat.
- Inside lighting.
- Bumper bars as standard.
- 70 mm. insulation (100% CFC free).
- Digital controllers.
- Copper tube evaporator and condenser.
- Built-in LED.

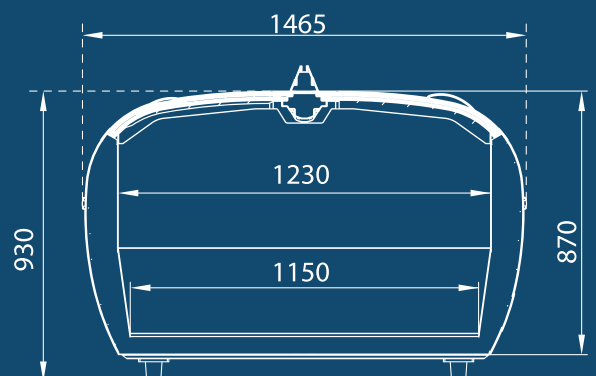
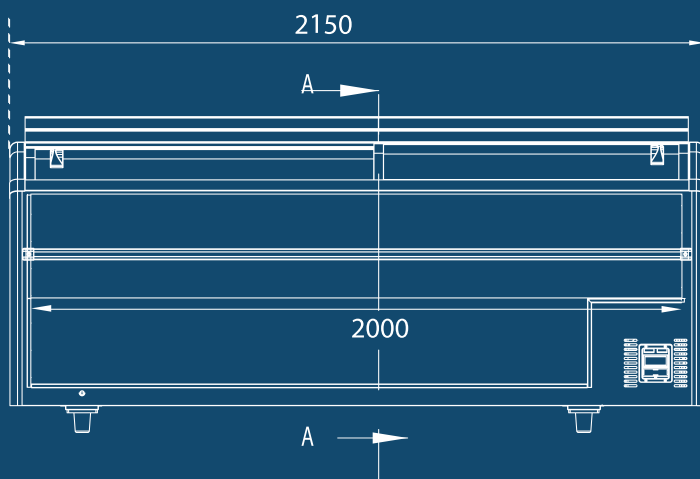

# DUPLA 2.2

## TECHNICAL SPECIFICATIONS





		DUPLA 2.2 DE	DUPLA 2.2 DEPN
<b>TECHNICAL DATA</b>			
Total Display Area (TDA)	m <sup>2</sup>	2.7	2.7
Climatic Class (EN23953)		3L1	3M1/3L1
Temperature Range	°C	-18/-28	+15/-26
Maintenance Free Condenser		✓	✓
Visual Alarm		✓	✓
HACCP - Hazard Analysis & Critical Control Points		✓	✓
Surveillance System		.	.
Net Volume	lt	1255	1255
Gross Volume	lt	1697	1697
<b>ELECTRICAL DATA</b>			
Voltage/Frequency	V/Hz	220/50	220/50
Rated Power	W	672	672
Rated Current	A	3.1	4.5
Energy Consumption	kWh/24h	9.2	9.2(-) / 4.6 (+)
Energy Efficiency Index (EEI)		26.70	26.70
Efficiency Class	A to G		
<b>REFRIGERANT DATA</b>			
Refrigerant Type		R290	R290
Number of Compressors	Un	2	2
Maximum Operating Pressure	bar	30	30
<b>DIMENSIONS &amp; WEIGHT DATA</b>			
Cabinet Dimensions	mm	2150x1465x930	2150x1465x930
Packaging Dimensions	mm	2240x1550x1050	2240x1550x1050
Net Weight	kg	198	198
Gross Weight	kg	251	251
<b>ACCESSORIES INCLUDED</b>			
Basket	Un	Not Available	Not Available
Large Divider	Un (code)	4 (AR211)	4 (AR211)
Small Divider	Un	Not Available	Not Available

# DUPLA TOPO

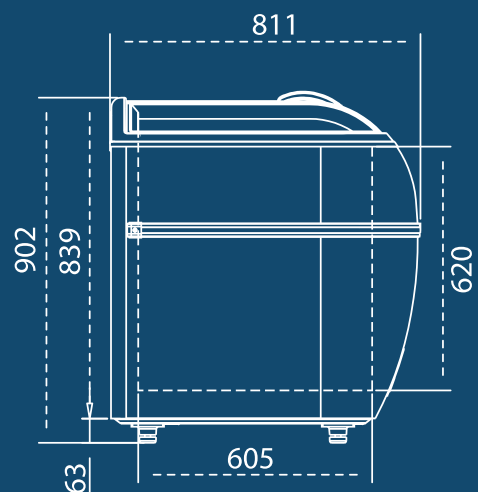
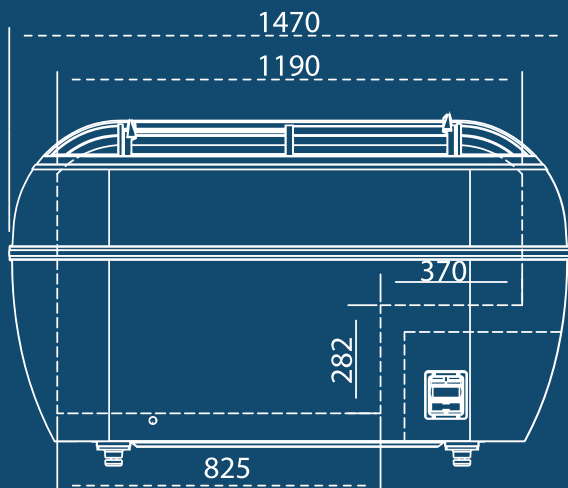
## TECHNICAL SPECIFICATIONS



		DUPLA TOPO DE	DUPLA TOPO DEPN
<b>TECHNICAL DATA</b>			
Total Display Area (TDA)	m <sup>2</sup>	0.7	0.7
Climatic Class (EN23953)		3L1	3M1/3L1
Temperature Range	°C	-18/-22	+15/-22
Maintenance Free Condenser		✓	✓
Visual Alarm		✓	✓
HACCP - Hazard Analysis & Critical Control Points		✓	✓
Surveillance System		.	.
Net Volume	lt	334	334
Gross Volume	lt	425	425
<b>ELECTRICAL DATA</b>			
Voltage/Frequency	V/Hz	220/50	220/50
Rated Power	W	387	484
Rated Current	A	1.8	3.0
Energy Consumption	kWh/24h	4.1	4,1(-) / 2,0(+)
Energy Efficiency Index (EEI)		34.9	34.9
Efficiency Class	A to G		
<b>REFRIGERANT DATA</b>			
Refrigerant Type		R290	R290
Number of Compressors	Un	1	1
Maximum Operating Pressure	bar	30	30
<b>DIMENSIONS &amp; WEIGHT DATA</b>			
Cabinet Dimensions	mm	1470x811x902	1470x811x902
Packaging Dimensions	mm	1530x920x1000	1530x920x1000
Net Weight	kg	85	85
Gross Weight	kg	125	125
<b>ACCESSORIES INCLUDED</b>			
Basket	Un	Not Available	Not Available
Large Divider	Un	1 (AR213)	1 (AR213)
Small Divider	Un	1 (AR214)	1 (AR214)



**CALL US**  
021 851 0511

**EMAIL US**  
INFO@COOLDISPLAYS.CO.ZA

**VISIT US**  
12 JULIAN WAY  
SOMERSET WEST BUSINESS PARK  
SOMERSET WEST, CAPE TOWN  
SOUTH AFRICA

