

# ECH FREEZER

COMMERCIAL DISPLAY FREEZER – SELF CONTAINED



# TABLE OF CONTENTS

**ABOUT THIS MODEL**

**1**

**ECH 2.5**

Size

Specifications

**2**

## ABOUT THIS MODEL



- Versions available:
  - (DE) freezer with automatic defrosting and water evaporation;
  - (DEPN) freezer/chiller with automatic defrosting;
- Interior and exterior in PVC coated galvanised sheet metal in accordance with food standards;
- Evaporator, condenser and the entire cold circuit in copper;
- Maintenance-free condenser;
- Great product visibility;
- Triple front and side glass with internal resistance to prevent condensation;
- False bottom adjustable in height;
- Equipped with variable speed compressor;
- LED lighting (with automatic control).

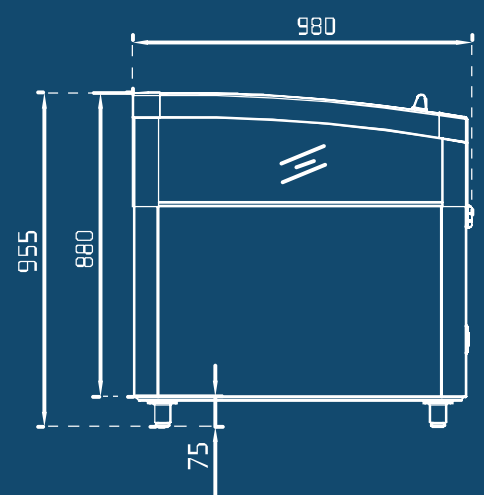
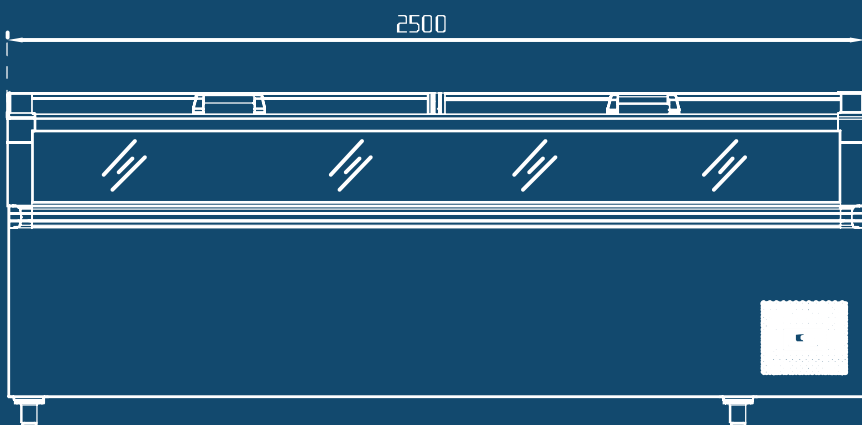

# ECH 2.5

## TECHNICAL SPECIFICATIONS



		ECH 2.5 DE	ECH 2.5 DEPN
<b>TECHNICAL DATA</b>			
Total Display Area (TDA)	m <sup>2</sup>	1,93	1,93
Climatic Class (EN23953)		3L1	3M1/3L1
Temperature Range	°C	-16/-25	+10/-25
Maintenance Free Condenser		✓	✓
EC Fan Motor		•	•
Visual Alarm		✓	•
Sound Alarm		✓	•
HACCP - Hazard Analysis & Critical Control Points		✓	•
Surveillance System LON-RS485		•	•
Net Volume	lt	821	821
Gross Volume	lt	1320	1320
<b>ELECTRICAL DATA</b>			
Voltage/Frequency	V/Hz	220-240/50-60	220-240/50-60
Rated Power	W	520	520
Rated Current	A	2.4	2.4
Energy Consumption	kWh/24h	9.15	9.15(-) / 3,8(+)
Energy Efficiency Index (EEI)		34.8	34.8
Efficiency Class	A to G		
<b>REFRIGERANT DATA</b>			
Refrigerant Type		R290	R290
Number of Compressors	Un	1	1
Maximum Operating Pressure	bar	30	30
<b>DIMENSIONS &amp; WEIGHT DATA</b>			
Cabinet Dimensions	mm	2500x980x955	2500x980x955
Packaging Dimensions	mm	2606x1066x1028	2606x1066x1028
Net Weight	kg	---	---
Gross Weight	kg	---	---



**CALL US**  
021 851 0511

**EMAIL US**  
INFO@COOLDISPLAYS.CO.ZA

**VISIT US**  
12 JULIAN WAY  
SOMERSET WEST BUSINESS PARK  
SOMERSET WEST, CAPE TOWN  
SOUTH AFRICA

